



TOWN OF LITTLETON

FINISH HABITABLE BASEMENT CHECKLIST

Directions

1. Submit two complete sets of required information
2. Draw a floor plan with dimensions drawn to scale, showing the layout of the entire basement. Label the use of all the rooms.

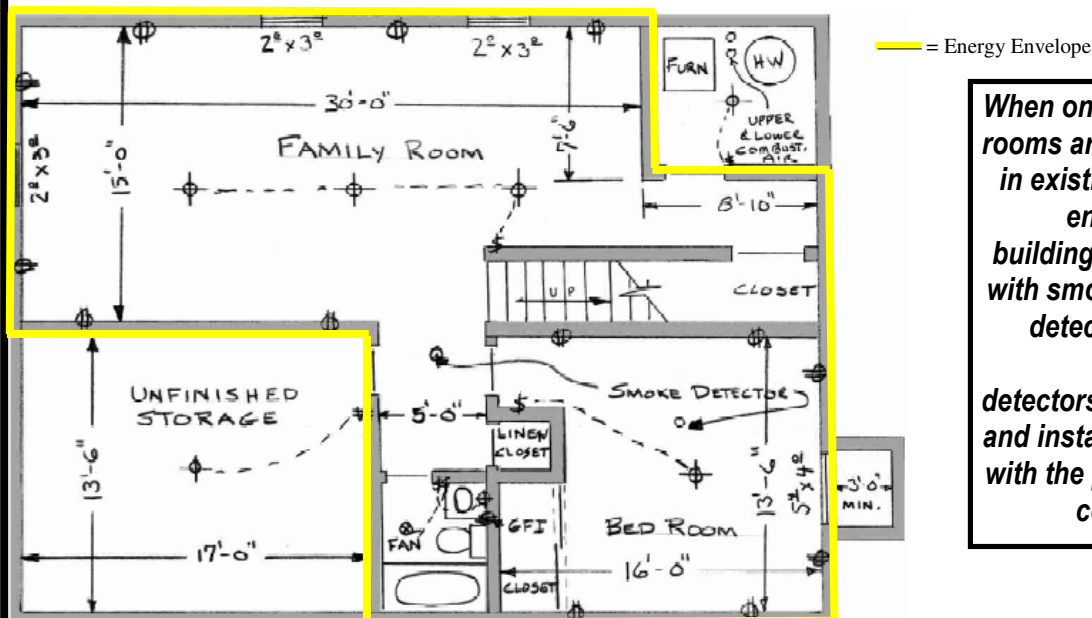

When one or more sleeping rooms are added or created in existing dwellings, the entire existing building shall be provided with smoke detectors, heat detector and carbon monoxide detectors designed, located and installed in accordance with the provisions for new construction

3. Show electrical outlets, service panel location, smoke detectors, carbon monoxide detectors, lighting, fans, plumbing modifications, cleanouts, furnace and water heaters.
4. Show emergency escape and rescue opening location; size, type and location of egress windows, egress window wells, and clear dimension of window wells and ladder location.
5. List all window and door sizes and type, with dimensions of clear opening provided.
6. Identify all modifications to existing structure such as post, girder, headers, floor joist, etc.
7. Indicate finished floor to ceiling height of all spaces, including height of existing and proposed girders and ductwork.
8. Show location and method of combustion air make-up
9. Show method and location of habitable space ventilation
10. Complete Energy Conservation Application Form and clearly show the perimeter of the energy envelope
11. Complete residential permit application

1. Ceiling Heights

- Finish floor to finish ceiling shall not be less than 7 feet (§5305)
- Beams and girders spaced not less than 4 feet on center may project not more than 6 inches into the required ceiling height (§5305)
- Minimum stairway headroom shall not be less than 6 foot 6 inches measured from the nosing of the stairs (§5311.5.2)
- A shower or tub equipped with a shower head shall have a minimum ceiling height of 6 feet 8 inches above a minimum area of 30 inches by 30 inches shower pan at the shower head. (§5305)

2. Emergency Escapes

- All habitable space and sleeping rooms within a basement shall have an emergency escape window or door located on the exterior of the building so that occupants may escape from that opening directly to the outside without having to travel through the building itself. (§5310)
- The door or window shall be operable from the inside without the use of special tools. All escape or rescue windows shall have a minimum clear opening area of 5.7 square feet. Double hung windows only shall be permitted to have a net clear opening of 20 x 24 in either direction. The maximum finished sill height shall be 44 inches above the finished floor. Exterior window areaways (window wells) provided for escape or rescue windows shall be at least 9 square feet and at least 36 inches out from the house. All window wells with a vertical depth of more than 44" shall be equipped with a permanently affixed ladder. (§5310.2)
- Bulkhead stairs and enclosures serving as the emergency escape shall comply with §5310.1, §5310.3, and §5311.5.8.2

3. Smoke / Carbon Monoxide detectors

- Smoke and Carbon Monoxide detectors are required in all basements, locations to be pre-approved by the Littleton Fire Department. (§5313)
- If the finished basement contains a sleeping room, a smoke alarm must be installed on the ceiling or wall inside the sleeping room, and in the hallway of area immediately outside the sleeping room. (§5313)
- If one or more sleeping rooms are added or created in existing dwellings, the entire building shall be provided with smoke detectors, heat detectors and carbon monoxide detectors in accordance with the provisions for new construction. (§9304.8)

4. Fuel Burning Devices

- Heating devices and water heaters can not be located in a bedroom or bathroom unless specifically approved and labeled for such applications. (§6701.4)
- All heating devices and water heaters located in space less than required by §6702 are required to be provided with outside combustion air. (§6702) & (§6703)

5. Fireblocking

- Fireblocking shall be provided to cut off all concealed draft openings, both vertically at the ceiling and floor levels and horizontally along the length of wall at intervals not to exceed 10 feet, and at all interconnections of concealed vertical and horizontal spaces such as intersection of stud walls and soffits or dropped ceilings. A detail of required fireblocking is provided on the following page. (§5602.8)

6. Insulation

- Complete the Energy Conservation Application Form For Energy Efficiency available in the Building Department. http://www.mass.gov/Eeops/docs/dps/appf/form_bbrs_energy_compliance_7th_ed_one_and_two_family_02_07_08.pdf (§6101.2)

7. Space Under Stairs

- If access to space under stairs is provided for storage or other uses, the walls and ceiling of this enclosed space must be finished with a minimum 1/2" Gypsum Wall Board. (§5311.2.2)

8. Light And Ventilation

- All habitable rooms are to be provided with natural light and ventilation by means of exterior glazed openings with an area of not less than (8%) of the floor area or artificial light as approved by the building official. Natural ventilation is required with minimum openable area of (4%) of the floor area being ventilated. For space unable to achieve the minimum required ventilation, a mechanical system in accordance with §5303.1 exception #1 is allowed. (§5303)
- At least one switch-controlled lighting outlet must be installed at each end of every hallway and stairway. (§5303.6)

9. Stairs

- All interior stairs shall comply with current edition code. (§5311.5)

Basement Finish Details

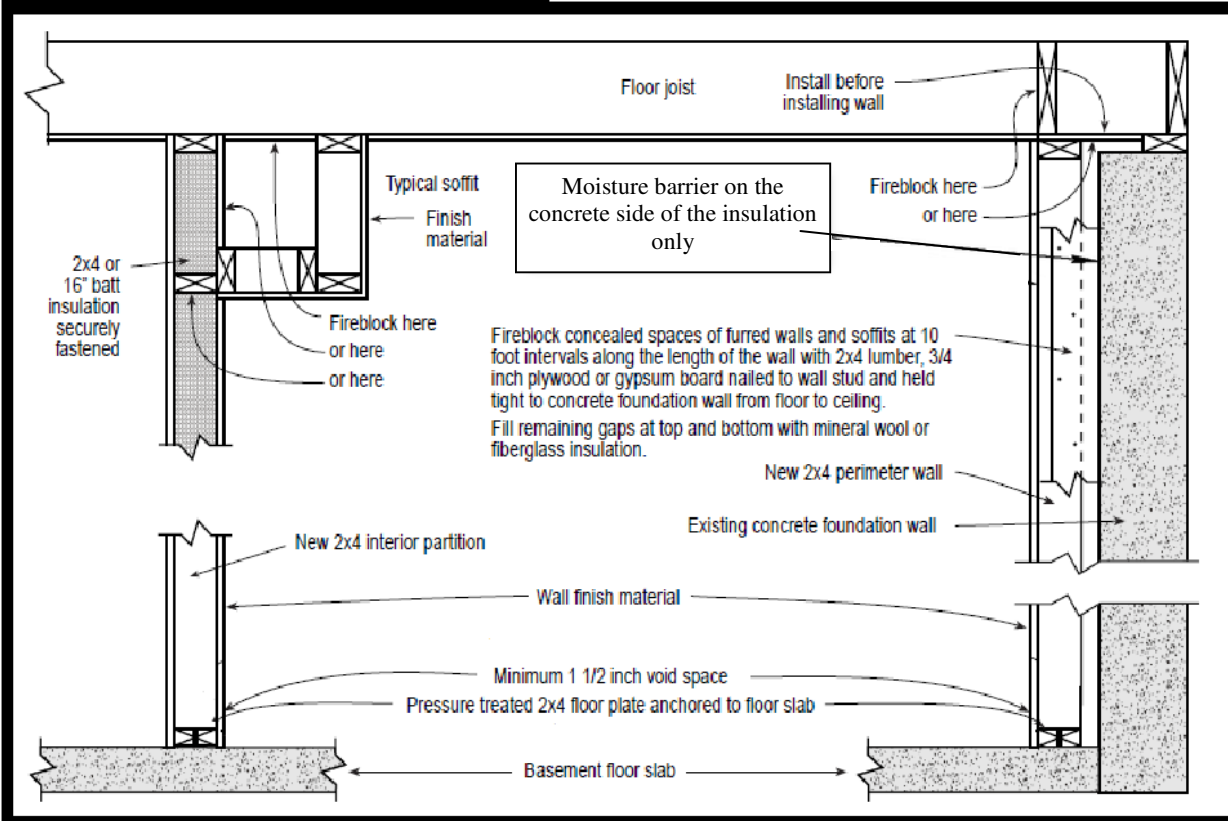

This prescriptive example assumes the prior application of damp-proofing or water-proofing on the exterior of the concrete foundation wall, and that the basement wall is historically dry. For concrete walls that have questionable dampness, replace the “*Moisture barrier between the foundation wall and the insulation, and the vapor barrier between the insulation and the interior*” with 2” Expanded Polystyrene insulation Rigid Insulation applied directly to the concrete wall with joints sealed with mastic or adhesive, then fill the stud cavity with unfaced insulation. Finish wall with normal Gypsum Wallboard and Latex Paint allowing a semi-permeable surface.

Emergency Escape & Rescue Window Well

Emergency Escape And Rescue window wells must provide a minimum area of 9 square feet with a minimum dimension of 36 inches and shall enable the window to open fully. If the depth of the window well exceeds 44 inches, a permanently affixed ladder must be provided. The ladder must not interfere with the operation of the window.

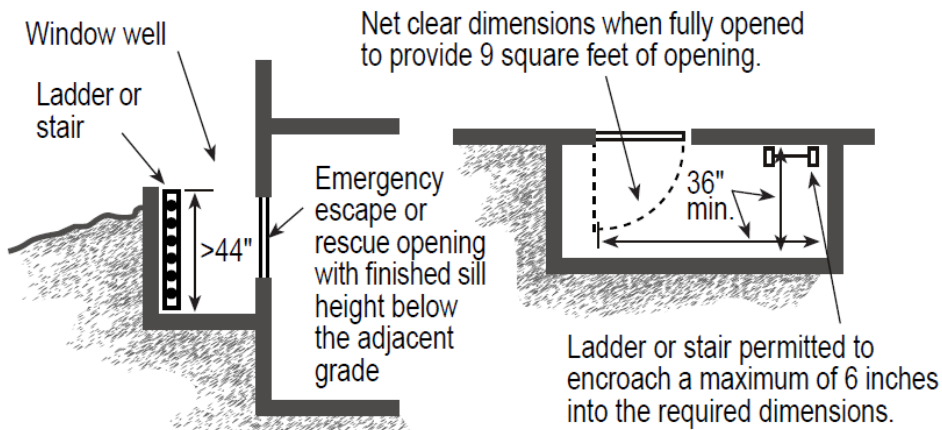

Emergency Escape & Rescue Window

Emergency Escape And Rescue Windows must meet the following criteria:

- * A minimum opening of not less than 5.7 square feet unless the window is a double hung meeting the criteria of section 5310.1.1, Exception 2.
- * Minimum clear opening of 20 inches by 24 inches in either direction.
- * A finished sill height of not more than 44 inches above the floor and should be openable from the inside with normal operation and without the use of tools, keys or effort.

Examples of Complying Height & Width Combinations

