

I:\CORPORATE\MARKETING\DRAINAGE SOLUTIONS\CADD DATA\DRAINAGE DETAILS\0-SLOTTED DRAIN DETAIL GRID.DWG 11/11/2021 4:23 PM

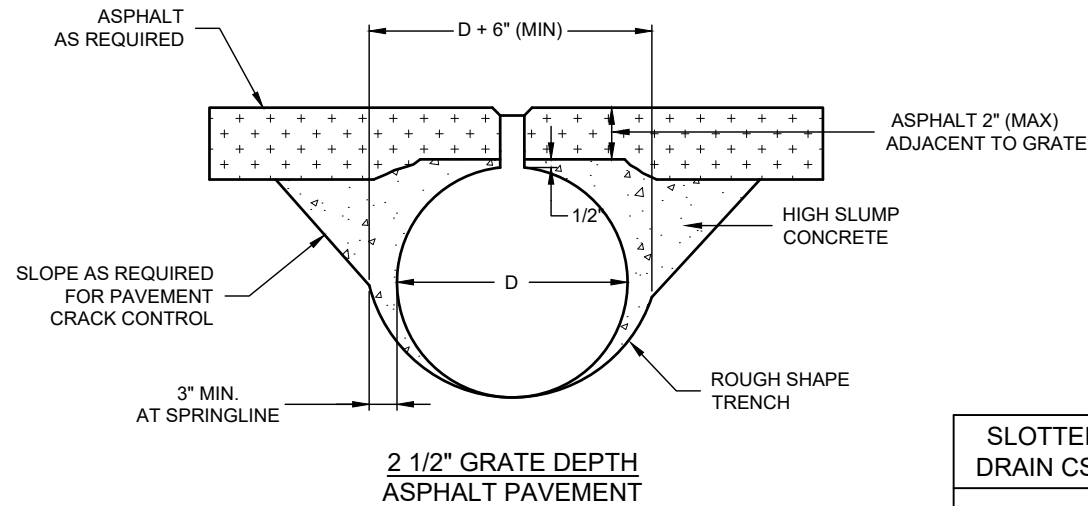
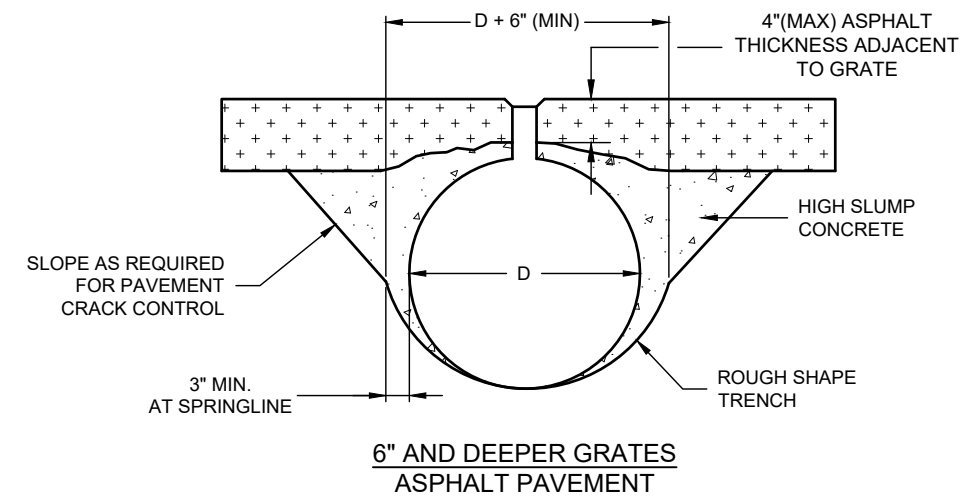
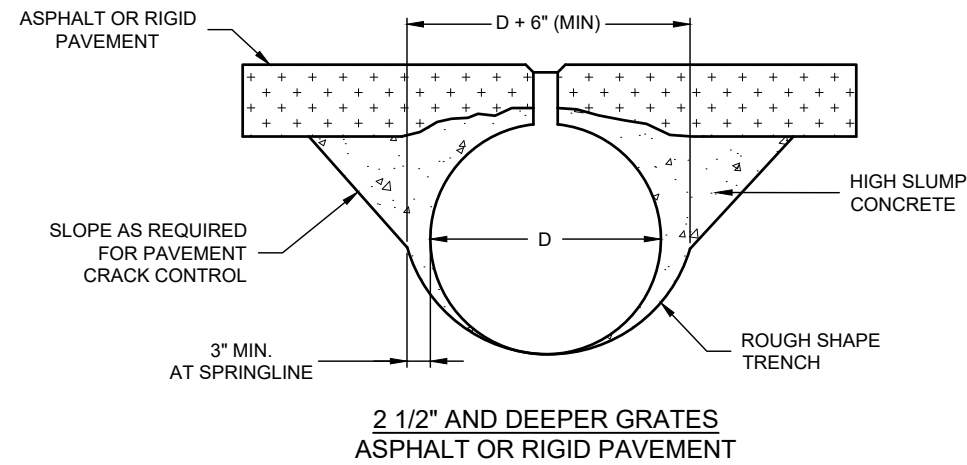

**SLOTTED DRAIN CORRUGATED STEEL PIPE
MINIMUM GAGE REQUIREMENTS
FOR HIGHWAY LOADS**

SLOTTED DRAIN CSP	2 1/2" GRATE		6" GRATE	
	ASPHALT PAVEMENT	CONCRETE PAVEMENT	ASPHALT PAVEMENT	CONCRETE PAVEMENT
12 - 36			16GA	

REQUIREMENTS:

- 1 EITHER 2-1/2" OR 6" DEEP GRATING IS ACCEPTABLE FOR STANDARD HIGHWAY (H10, H20, H25 & HL93) LOADS USING THE GAGES IN THE TABLE TO THE RIGHT. HIGH SLUMP CONCRETE BACKFILL IS REQUIRED WITH THE ENVELOPE EXTENDING A MINIMUM OF 3 INCHES BEYOND THE SPRINGLINE, AS SHOWN ABOVE. THE HIGH SLUMP CONCRETE MUST PROVIDE A MINIMUM OF 750 PSI COMPRESSIVE STRENGTH.
- 2 FOR INSTALLATION SUBJECTED TO OCCASIONAL LIGHT VEHICLE (LESS THAN H10) LOADS, SELECTED GRANULAR BACKFILL MAY BE USED. HOWEVER, THE SLOTTED DRAIN MUST BE SET IN A TRENCH WIDE ENOUGH TO PROPERLY HAUNCH THE PIPE (TYPICALLY D + 36"). THE GRANULAR BACKFILL MUST BE CLEAN, NON-PLASTIC, WELL GRADED MATERIAL, COMPACTED TO 95% STANDARD PROCTOR DENSITY.
- 3 DURING INSTALLATION, RECESS THE TOP OF THE GRATE 1/4" BELOW THE FINISHED GRADE OF THE PAVEMENT.
- 4 PAVEMENT DESIGNS BY OTHERS. FOR REINFORCED CONCRETE PAVEMENTS, CONTINUE THE REINFORCEMENT OVER THE SLOTTED DRAIN. FOR UNREINFORCED CONCRETE PAVEMENTS, MINIMUM SHRINKAGE STEEL IS RECOMMENDED.
- 5 HEAVIER WHEEL LOADS REQUIRE THE USE OF MINIMUM 6" DEEP GRATING AND TYPICALLY A LARGER HIGH SLUMP CONCRETE EMBEDMENT ZONE. (SEE AIRCRAFT & HEAVY LOADING DETAIL).

NOTES:

1. INSTALLATION MUST CONFORM TO STANDARD INSTALLATION DETAILS USING A 750 PSI MINIMUM HIGH SLUMP CONCRETE BACKFILL.
2. REQUIRES A REINFORCED CONCRETE PAVEMENT OR A DEEPER GRATE.

BACKFILL DETAIL FOR HIGHWAY LOADING

NOT TO SCALE

0-SLOTTED DRAIN DETAIL GRID

The design and information shown on this drawing is provided as a service to the project owner, engineer and contractor by Contech Engineered Solutions LLC ("Contech"). Neither this drawing, nor any part thereof, may be used, reproduced or modified in any manner without the prior written consent of Contech. Failure to comply is done at the user's own risk and Contech expressly disclaims any liability or responsibility for such use.

If discrepancies between the supplied information upon which the drawing is based and actual field conditions are encountered as site work progresses, these discrepancies must be reported to Contech immediately for re-evaluation of the design. Contech accepts no liability for designs based on missing, incomplete or inaccurate information supplied by others.

MARK	DATE	REVISION DESCRIPTION	BY

CONTECH
ENGINEERED SOLUTIONS LLC
www.ContechES.com
9025 Centre Pointe Dr., Suite 400, West Chester, OH 45069
800-338-1122 513-645-7000 513-645-7993 FAX

CONTECH
PIPE SOLUTIONS
CONTECH
CONTRACT
DRAWING

**SLOTTED DRAIN
BACKFILL DETAIL FOR HIGHWAY LOADING**

PROJECT No.:	SEQ. No.:	DATE:
DESIGNED:	DRAWN:	
CHECKED:	APPROVED:	
SHEET NO.:	3	OF 6